

AUTOMATIC LANE BARRIER

FEATURES

- ~ Halfway Reverse Action Ready
- ~ Both Left and Right Orientation
- ~ Arm Swing Open on Heavy Impact
- ~ Intelligent Embedded Barrier Controller
- ~ Arm Vibration Compensation with Spring Mechanism
- ~ Barrier Arm Cover with Protective Foam & Reflective Stripe
- ~ Auto-Power Cut-Off Time Limit to Prevent Motor from Over Heating

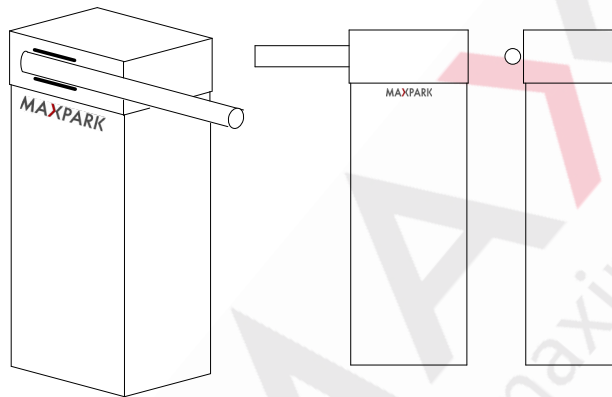

SPECIFICATION

Boom Length:	3 Meter
Opening & Closing Time	1.8 sec.
Voltage:	230V
Frequency:	50/60Hz
Power Consumption:	120W
Dimensions:	370 x 280 x 1080 mm
Weight:	55kg

